



OPERATIONAL MANUAL

Liberty Bingo Console

Table of Contents

CHAPTER 1 (pg 3)

- 1.0 Unpacking
- 1.1 Damage Action Process
- 1.2 Warranty Assurance

CHAPTER 2 (pg 4)

- 2.0 Introduction

CHAPTER 3 (pg 5-6)

- 3.0 Setting Up the Console
- 3.1 Playing Bingo with the Console

CHAPTER 4 (pg 7-9)

- 4.0 Maintaining the Console
- 4.1 Cleaning the Exterior
- 4.2 Replace the Air Filter
- 4.3 Replace Power Fuse
- 4.4 Blower Removal
- 4.5 Blower Maintenance

CHAPTER 5 (pg 9)

- 5.0 Replacement Parts & Accessories

CHAPTER 6 (pg 10-11)

- 6.0 Warranty

Liberty™ Bingo Console Manual

2015© Capitol Bingo Equipment. All Rights Reserved.

Capitol® Bingo Equipment Division
9900 Clinton Road
Cleveland, Ohio 44144

Unpacking

Capitol Bingo Equipment designed your new Liberty Bingo Console to have a distinctively attractive appearance, and we used careful manufacturing and assembly techniques to preserve this appearance. Each Liberty Bingo Console is inspected for scratches, bumps or abrasions during packing, and is warranted to be free from defects.

Damage Action Process

Your Capitol Bingo Equipment contains delicate electronic equipment. It is imperative that you thoroughly inspect the contents of the package before accepting product delivery from the carrier.

In case of severe damage, refuse the equipment from the carrier. Contact your local Capitol Bingo Equipment distributor for immediate replacement.

If the product is damaged but acceptable, make a note on the bill of lading before accepting. Take a photo of the damage before and after unpacking as a record of claim against the carrier. Contact the carrier's agent immediately for inspection. Be sure to obtain a copy of the inspection report for your records.

Warranty Assurance

You must keep a copy of your receipt or invoice for proof of purchase. Please review the warranty information on page 10 of this manual.

If there are any questions, contact your distributor or call Technical Assistance:

Technical Assistance Center
1-800-277-6214

INTRODUCTION

Thank you for choosing Capitol Bingo as your supplier of charitable gaming equipment and supplies. This product was designed and manufactured to the highest standards to provide you with many years of bingo excitement. We hope that you will enjoy the use of the Liberty™ Tabletop Bingo Console. Please read and become familiar with this Operator's Manual prior to setting up and/or operating the unit.

CAUTION:

Please take great care when unpacking the Liberty Bingo Console from the packing material. Cutting the packing material too aggressively may lead to console damage.

Before opening, closely inspect the carton for evidence of shipping damage such as puncture holes, tears, and crushed edges or corners.

Damage to the carton may mean damage to the Liberty. If damage is detected refer to the Damage Action Process section (pg. 3) for procedures.



**PLEASE TAKE CARE WHEN
UNPACKING THE LIBERTY
BINGO CONSOLE FROM THE
PACKAGING MATERIALS!**

SETTING UP THE CONSOLE

1. Prior to using the bingo console for the first time, remove all of the bingo balls from their shipping bag.
 - A. To access the ball chamber, lift the rear door until it is able to rotate downward and lower the door as shown in Fig. 4.
 - B. To close the rear door, reverse the procedure outlined above making sure that the pin on the inside of the door engages with the hole in the top of the bingo console.
2. For proper operation, the console must rest on a level, stable surface strong enough to support the weight of the unit. This bingo console weighs approximately 35 lbs/16 Kg.
3. Install the supplied power cord as shown in Fig. 5 Item 'C'. As with all electrical equipment, care should be taken to prevent damage to the cord and its insulation. Inspect the cord before each use for cuts, abrasions or any other damage that may compromise its ability to function safely.

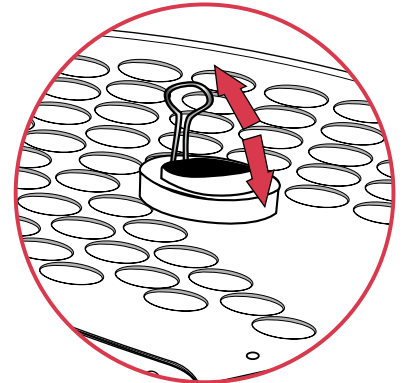

Fig.3

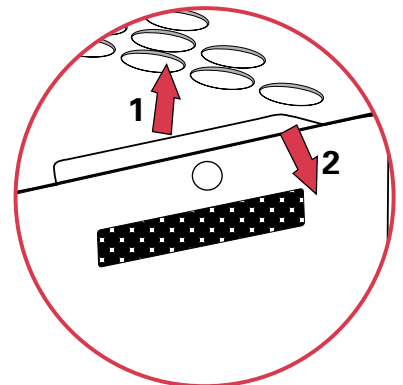

Fig.4

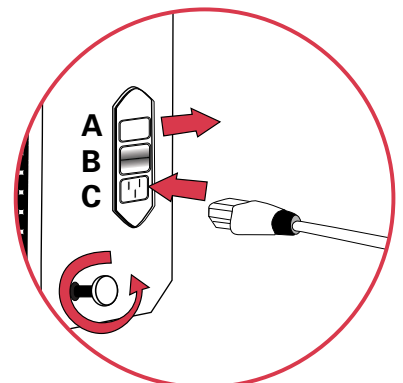

Fig.5

PLAYING BINGO WITH THE CONSOLE

1. The main power switch for this bingo console is located on the rear panel of the unit as shown in Fig. 5 Item 'B'. This switch operates both the blower motor as well as the ball chamber light. The ball chamber light can be switched off independently of the blower motor by using the secondary switch located directly on the light fixture inside the ball chamber.
2. During operation, bingo balls will be blown up the ball tube and will be held captive at the top of the ball tube by the ball stop. The bingo ball can be removed from this position by gently pulling it toward you at a slight upward angle. The ball stop has limited adjustability to increase or decrease its hold on the bingo balls. By firmly grasping the end of the ball stop with one hand and holding the top of the ball tube with the other hand, the wire can be gently bent as shown in Fig 3. Bending the ball stop upward will decrease its hold on the ball; bending it downward will increase its hold. Adjustment should be made in small increments and with great care.
3. The ball tray has an arched configuration consisting of five rows, each with fifteen holes. Each of the 75 holes is labeled with a unique letter-number combination. As each bingo ball is called and removed from the ball tube, it can be placed in its respective position in the ball tray. Although not required, verification of a bingo will be made easier if the balls are placed in the holes with their numbers visible to the caller.

PLAYING BINGO WITH THE CONSOLE (CONTINUED)

4. At the conclusion of the bingo game, the bingo balls can be returned to the ball chamber by actuating the ball tray release mechanism. The blower motor must be turned OFF to prevent bingo balls from being blown into the ball release trays while they are closing. The ball tray release mechanism is designed with a locking feature that will help prevent unintentional release of the bingo balls. To actuate the ball tray release mechanism:
- Simultaneously pull both ball tray release knobs outward as shown in Fig. 1 and indicated by Arrow '1'.
 - While holding the ball tray release knobs out, push the knobs downward, allowing them to follow a semi-circular path as shown in Fig. 1 and indicated by Arrow '2'.
 - After all of the balls are returned to the ball chamber, return the ball tray release knobs to their original position making sure that they retract into the locked position.

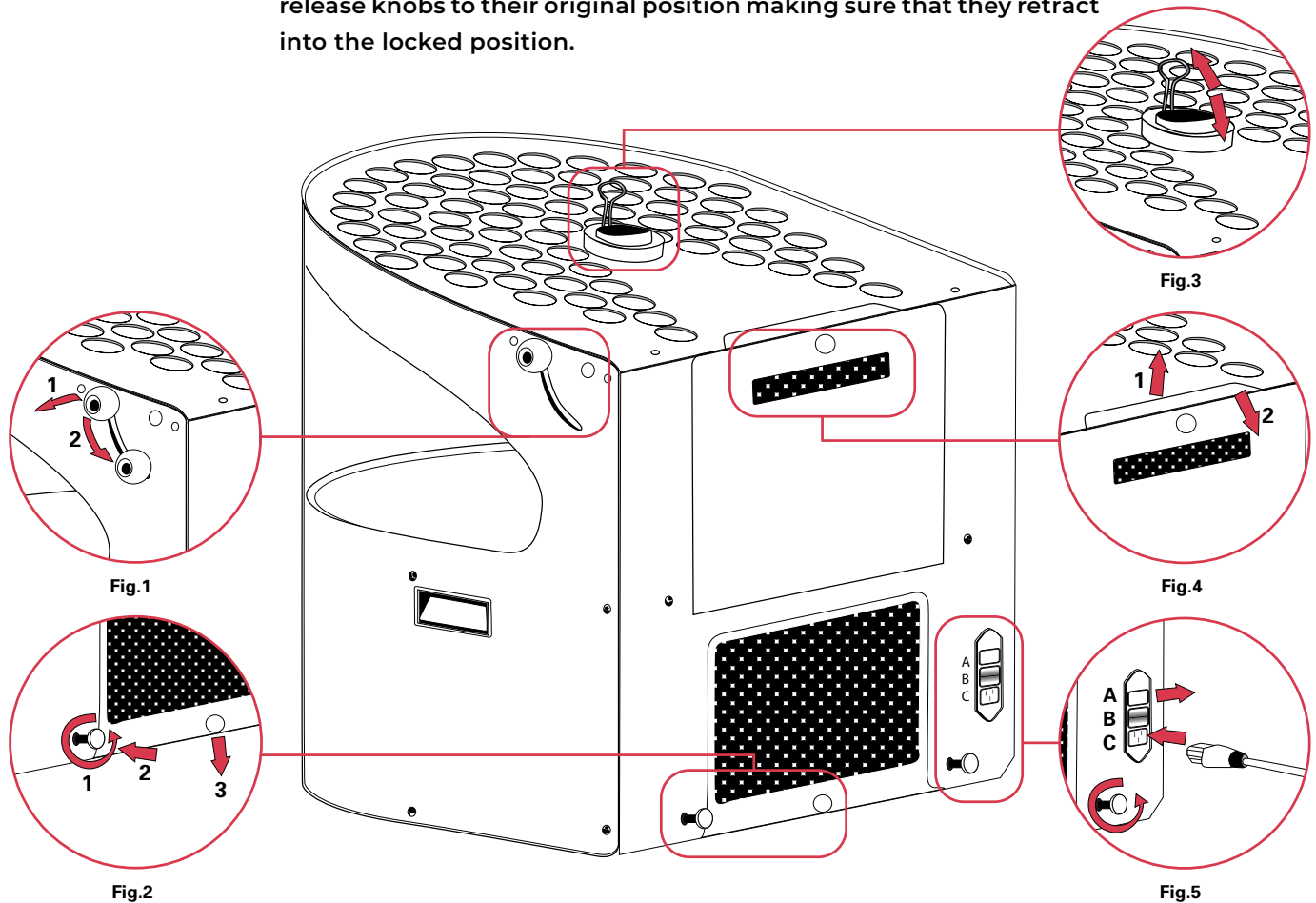

CAUTION: Do not close the ball tray release mechanism if there are any bingo balls that did not return to the ball chamber. They may be crushed and/or damaged by the closing process.

MAINTAINING THE CONSOLE

To ensure the longevity of your Liberty™ Bingo Console, please read the following pages for simple maintenance procedures and cleaning techniques. To extend the life of your bingo console, routine maintenance is needed to keep the machine in proper working order.

CLEANING THE CONSOLE EXTERIOR

Unplug the unit prior to cleaning to prevent the risk of electrocution. Failure to disconnect power could result in injury and/or death, and possible damage to your bingo equipment.

The exterior of your bingo console is manufactured from durable plastics. Although this is a very long lasting material, care must be taken to maintain its lustrous appearance. Use a mild detergent and a damp sponge or cloth to clean it. Light stains and fine scratches may be removed by using Novus® Plastic Polish #2 according to the manufacturer's instructions.

Do not use glass cleaning products, acetone, gasoline, benzene, lacquer thinner, chlorinated solvents, gritty abrasive scouring compounds, or alkaline cleaners to clean the exterior of your bingo console as damage to the plastic may occur.

REPLACE THE AIR FILTER

Your console includes an air filter installed to prolong the life of the blower motor. Do not operate this bingo console without a clean air filter installed. A dirty air filter may degrade the unit's performance and reduce the life of the blower. It should be replaced every 6-12 months depending upon the frequency of use of the unit. To change the air filter:

1. Unplug the unit and position the bingo console with the rear 2" overhanging the edge of a suitable work surface.
2. Unscrew both thumbscrews on the rear of the bingo console 25-30 full turns (counter-clockwise rotations) as shown in Fig. 2 on page 6 and indicated by Arrow '1'.
3. Simultaneously push both thumbscrews in until they return to a position flush with the backpanel of the unit, as shown in Fig. 2, page 6 by Arrow '2'.
4. The air filter and the air filter carrier should now be free to drop vertically out of the bottom of the unit.
5. Remove the air filter from the air filter carrier and replace it with a new air filter.
6. Reverse the operations identified above to reinstall the filter and to return the unit to

REPLACING THE POWER FUSE

This bingo console is equipped with a fused power entry module. In the event that the fuses need to be replaced, proceed as follows:

1. After unplugging the unit from the electrical supply and removing the power cord from the power entry module, position the bingo console on a suitable work surface.
2. Remove the fuse drawer from the power entry module as shown on page 6, Fig. 5, Item 'A' by actuating the fuse drawer release just above the ON/OFF switch.
3. Replace fuses with Littelfuse 0215004.HXP or 5 mm x 20 mm, 4A, 250V UL equivalent approved fuses.
4. Return the fuse drawer to power entry module making sure that the fuse drawer 'clicks' into the closed position.
5. Reinstall power cord as outlined on page 5, Chapter 3: Setting Up the Console.

UNPLUG THE UNIT PRIOR TO REPLACING THE POWER FUSE TO PREVENT THE RISK OF ELECTROCUTION. FAILURE TO DISCONNECT POWER COULD RESULT IN INJURY AND/OR DEATH, AND POSSIBLE DAMAGE TO BINGO EQUIPMENT.

BLOWER REMOVAL

Please make sure to remember to turn off your blower unit and unplug it from the wall. Failure to disconnect power could result in injury and/or death, and possible damage to your bingo equipment.

Only a qualified repair person should service the blower motor installed in this bingo console. Contact information for technical assistance can be found on the manufacturer's label affixed to the rear of the bingo console and on page 3 of this manual.

1. Remove the air filter. (See page 7, Replacing The Air Filter, for instructions)
2. Remove the four screws holding the blower to the base pan. (See Fig. 1 & Fig. 2, page 9)
3. Disconnect the quick-disconnect connectors from the terminals in the bottom of the blower compartment. (Close proximity to the power switch)
4. Gently maneuver the blower motor out of the air filter opening.

BLOWER MAINTENANCE

1. Perform the “Blower Removal” steps outlined in the previous section.
2. Check the blower squirrel cage for any debris and clean as needed with a stiff brush and vacuum. If needed, the cage can be loosened with a 1/8” Allen wrench and removed from the shaft.
3. Place a few drops of quality 20W oil into the **oiling ports of the motor** see reference picture below.

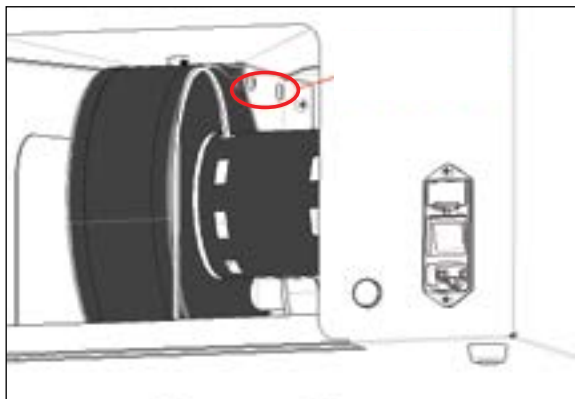

Fig.1

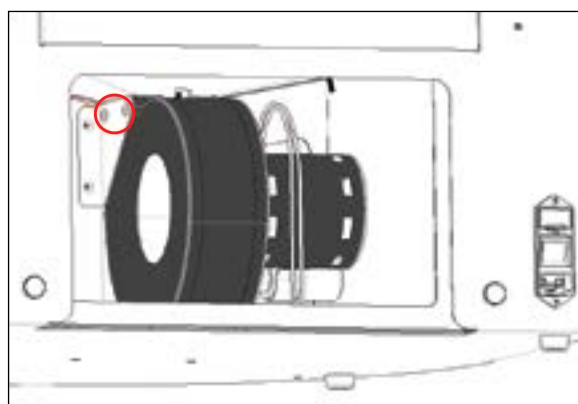
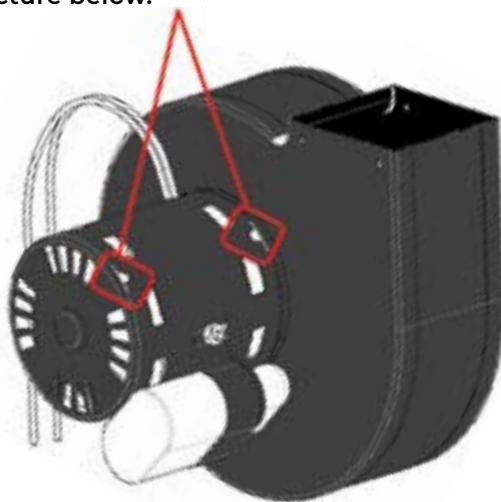

Fig.2

REPLACEMENT PARTS & ACCESSORIES

Replacement/Service Parts For Your

Air Filter	Part # HH246	Light Fixture w/Lamp	Part # HH525
Fuses	Part # HH1403	Ball Tube Assy	Part # HH1407
Power Cord	Part # HH952	Blower Motor	Part # 41620
Bingo Balls	Part # HH644		

Available Accessory For Your Console:

Rolling Base Unit Part # HH1261

WARRANTY

Capitol® Bingo Console Standard Limited Warranty

Set out below are the terms of the Standard Limited Warranty ("Limited Warranty") made by Arrow International, Inc. ("Arrow") in connection with the sale of the Capitol® Bingo Equipment (the "Equipment").

1. Limited Warranty

Arrow warrants to the original purchaser ("Purchaser") that the Equipment will, for a period of ONE (1) YEAR from the date of shipment of the Equipment from Arrow, be free from manufacturing defects in material and workmanship. Purchaser represents to Arrow that no employee, agent, or representative of Arrow (or an Arrow dealer) has made any representation or warranty regarding the Equipment except as set out herein.

This Limited Warranty applies to normal commercial use and does not cover failures or damage which (a) occurs in shipment; (b) are caused by products not supplied by Arrow; or (c) results from accident, misuse, abuse, neglect, mishandling, misapplication, alteration, setup adjustments or modifications. This Limited Warranty also does not cover any damages resulting from failure to install the Equipment in strict conformity with local fire and building codes and regulations, or if the installation does not comply with the installation instructions provided by Arrow.

2. Disclaimer of Warranties

ARROW MAKES NO WARRANTIES, EXPRESS OR IMPLIED (INCLUDING, WITHOUT LIMITATION, MERCHANTABILITY, FITNESS FOR PARTICULAR PURPOSE, OR AGAINST INFRINGEMENT OF ANY PATENT), EXCEPT AS EXPRESSLY PROVIDED HEREIN. THE EXPRESS WARRANTIES PROVIDED HEREIN ARE IN LIEU OF AND EXCLUDE ALL OTHER WARRANTIES, GUARANTEES OR REPRESENTATIONS, EXPRESS OR IMPLIED, WHETHER ARISING BY OPERATION OF LAW OR OTHERWISE.

3. Limitation of Remedies

If the Equipment supplied does not conform to the Limited Warranty set out above, Arrow will, at its option, (a) repair or replace the Equipment, or part thereof, which is defective, or (b) refund so much of the purchase price as Purchaser has paid for the defective Equipment, less 1/12th of the purchase price for each month between the date of purchase from an authorized Arrow dealer and the date of the discovery of the defect, provided that written notice of the defect and its nature is given to Arrow as soon as practical after discovery of the defect, but in no event later than 90 days from the date of the discovery of the defect. All part repairs are through the Arrow Cleveland Depot.

4. Limitation of Liability

The remedy of repair, replacement, or refund of the purchase price is purchaser's sole and exclusive remedy and will satisfy all of Arrow's liabilities, whether based on contract, negligence, tort, product liability, strict liability or otherwise. IN NO EVENT WILL ARROW BE LIABLE FOR INCIDENTAL OR CONSEQUENTIAL DAMAGES, NOR WILL ITS LIABILITY IN CONNECTION WITH ANY EQUIPMENT OR SERVICE SOLD (INCLUDING NONDELIVERY OR LATE DELIVERY THEREOF) EXCEED THE SALE PRICE OF SUCH EQUIPMENT OR SERVICE.

5. Warranty Voided

Any obligations of Arrow under this Limited Warranty will be deemed to have been satisfied if anyone other than an authorized Capitol® Bingo Equipment Dealer services the Equipment.

6. Transfer of Limited Warranty

Purchaser may transfer its rights under this Limited Warranty subject to the terms and conditions hereof, to a buyer from Purchaser of the Equipment. Thereafter, the rights under this Limited Warranty are not transferable from Purchaser of the Equipment. There after, the rights under this Limited Warranty are not transferable.

For the transfer by Purchaser of the Limited Warranty to be effective, the following conditions must have occurred no later than the 30th day following the date of resale to Buyer:

- A. Purchaser must have complied with all requirements to make the Limited Warranty effective as to Purchaser; and
- B. The Equipment (as an entire unit and as purchased by Purchaser) must be transferred to Buyer.

WARRANTY

7. Inspection

With respect to any claim that the Equipment is defective, Arrow will be allowed a reasonable time to inspect the Equipment, in place. If the Equipment is altered or removed before Arrow has made such inspection or waived its right to do so, the obligations of Arrow under this Limited Warranty will be deemed to have been satisfied.

8. Proof of Purchase

Notwithstanding anything to the contrary in this Limited Warranty, Purchaser must, upon Arrow's request, submit proof of purchase (satisfactory to Arrow) of the Equipment. The Limited Warranty set out above shall not apply to, nor cover, any Equipment for which Purchaser is unable, upon Arrow's request, to supply such proof of purchase.

9. Limitation of Actions

Any legal action against Arrow for a default of its obligations under this Limited Warranty must be commenced within two years from the date the Equipment was sold by an authorized dealer of the Equipment.

10. How to Obtain Service

If a Problem with this Equipment develops during or after the warranty period, proceed as follows:

- A. Refer to your Operator's Manual and follow the Troubleshooting Table within the "Service Section."
- B. Contact the authorized Capitol® Bingo Equipment Distributor from whom you purchased the Equipment.
- C. Contact the Capitol® Bingo Equipment Service Manager at the most convenient phone number listed below:

1(800) 321-0757 outside Ohio, but within the U.S.A.

1(800) 277-6214 anywhere in the U.S.A or Canada

1(800) 537-3479 within the state of Ohio

1(216) 961-3500 within the 216 area code or outside the continental U.S.A.

1(216) 961-3641 fax number in Cleveland, Ohio

SERVICE CALLS WHICH DO NOT INVOLVE DEFECTIVE MATERIALS OR WORKMANSHIP AS DETERMINED BY ARROW IN ITS SOLE DISCRETION ARE NOT COVERED. THE COST OF SUCH SERVICE CALLS IS THE RESPONSIBILITY OF THE PURCHASER.

Arrow wants you to remain a satisfied customer. If a problem occurs that cannot be resolved to your satisfaction, please contact us immediately, phone one of the numbers listed above or write to:

Capitol® Bingo Equipment Division
C/o National Service Manager
9900 Clinton Road
Cleveland, Ohio 44144

Please be sure to include the name, model number, serial number, date of original purchase, and the distributor from whom you purchased the Equipment, as well as any actions taken to correct the problem.



arrowinternational.com

Phone Support Hours: 8am to 12am
1-800-277-6214

Part # HH1260-MNL
Revision March 11, 2020

